

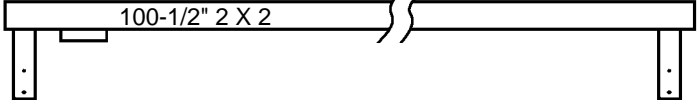

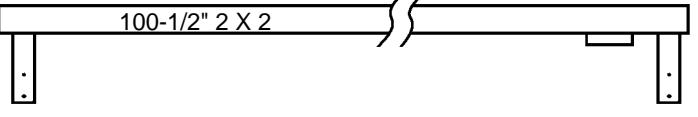







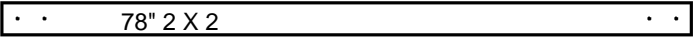
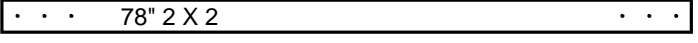
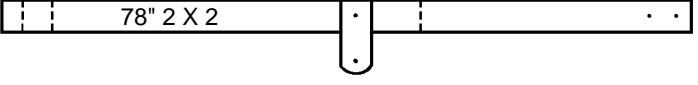
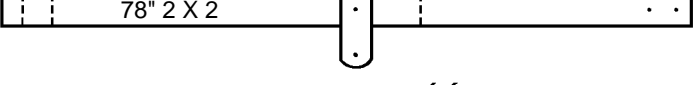
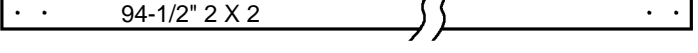
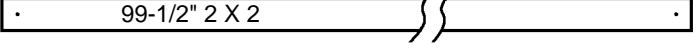

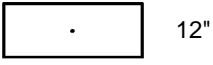

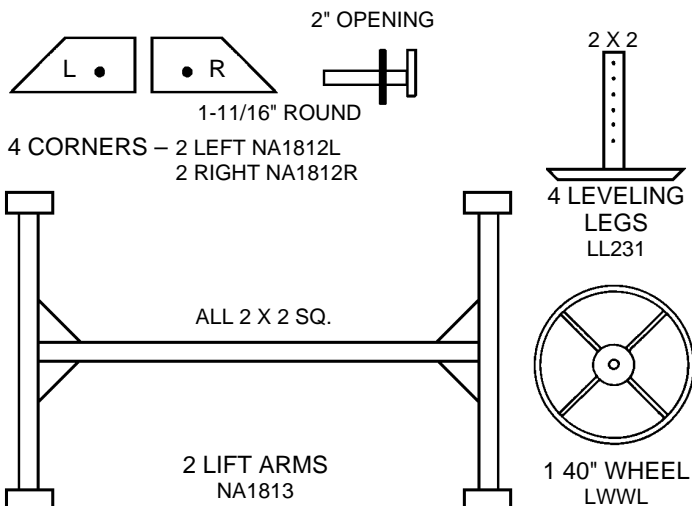
1800 LB. (96" x 101") ALUMINUM PARTS LIST

L0A18-096

| | | |
|----------------------------|---------|--|
| 2 PULL ARMS (ONE PAIR) | NAL1202 |  |
| | NAR1202 |  |
| 2 TOP CROSS ARMS | NA1803 |  |
| 1 BOTTOM BACK CROSS ARM | NA1203 |  |
| 1 BOTTOM FRONT CROSS ARM | NA1204 |  |
| 1 WINCH ARM | NA1807 |  |
| 1 FRONT UPRIGHT | NA1807 |  |
| 2 BOTTOM SIDES | NA1808 |  |
| 2 SIDE 45° BRACES | NA2409 |  |
| 2 FRONT SIDE BRACES | NA1009 |  |
| 4 2" X 6" WOOD CRADLES | LCR0 |  |
| 2 2" X 6" WOOD KEEL BOARDS | LCRK |  |



HARDWARE & WINCH BAG – NA1850

| | |
|---|---|
| 1 Cable 24' x 1/4" – LIC241 | 1 1/4" Cable Clamp – LICC1/4 |
| 1 B1500 Winch – LWB15 | 2 1/2" Lock Nuts – NN12L |
| 1 D&L Winch Bolt Bag – LWBBS | 1 Moisture Bag |
| 1 2" Sheave – LIPS2  | 1 Assembly Instructions – NAASSYS |
| 2 Small Bushings – LIBS  | 1 BOLT BAG – NA18BB |
| 2 2" Complete Pulleys – LIP2S | 2 1/2" x 4" Bolts – NB124G |
| 1 Guide Pulley Side Plate – LIPSP  | 16 3/8" x 2-1/2" Bolts – NB38212G |
| 4 2 x 2 Aluminum Blocks – LCRB2  | 28 3/8" x 3" Bolts – NB383G |
| 1 Winch Reinforcement Plate – LCRKP  | 3 3/8" x 3-1/2" Bolts – NB38312G |
| 4 5" Keel plates – LCRKP  | 4 3/8" x 4" Bolts – NB384G |
| 8 Cradle Side Plates – LCRSP10S  | 4 3/8" x 2-1/2" Carriage Bolts – NB38212C |
| 1 Spinner Knob w/bolt – LKNOB | 4 3/8" x 2-1/2" Carriage Bolts – NB38412C |
| 4 3/8" x 2-1/2" Leg Pins with clips – LLP2/2 | 8 3/8" x 4-1/2" Carriage Bolts – NB38412C |
| 4 2 x 2 Rubber Caps – DIRC2SQ | 63 3/8" Nuts – NN38S |

"Quality Since 1971"

HEWITT MACHINE & MFG, INC. Box 111 Nicollet, MN 56074 (507) 225-3421

www.hewitt-roll-a-dock.com e-mail: info@hewitt-roll-a-dock.com



1200 lb. - 3000 lb. ALUMINUM LIFT

Assembly Instructions

Refer to enclosed parts list for description of parts and hardware. Note: The appearance of parts in the assembly diagrams may vary somewhat for different size lifts.

STEP 1: Separate all the bolts, nuts and other hardware from the supplied bag. The $\frac{1}{2}$ " x 4" bolts (or $\frac{1}{2}$ " x 4 $\frac{1}{2}$ ") are used for securing the pulley assemblies into the pull arm pulley boxes. The carriage bolts are used to secure the wood cradles and keel boards to the top cross arms.

Use the shortest bolt possible at each assembly point. For easier setup, assemble the lift on a flat and level surface. Leave nuts finger tight until assembly is completed. If a bolt is difficult to insert, tap with a hammer or use a punch to line up the holes.

Refer to diagram below for Steps 2 – 4.

STEP 2: Insert leveling legs completely through each of the four corner brackets. If a longer pair of leveling legs is supplied, they should be inserted into the rear corner brackets (deep water end of the lift). Insert a leg pin into each corner bracket to set the leg height. Place a rubber cap on the top (open end) of each leveling leg. Legs are optional on 1200lb. lift.

STEP 3: Push the round tube attached to the corner brackets through the bottom ends of the lift arms and into the bottom cross arms. Secure each corner to the bottom cross arms with two bolts and nuts.

STEP 4: Connect the front and rear corners for each side to one bottom side. Secure each corner with two bolts and nuts.

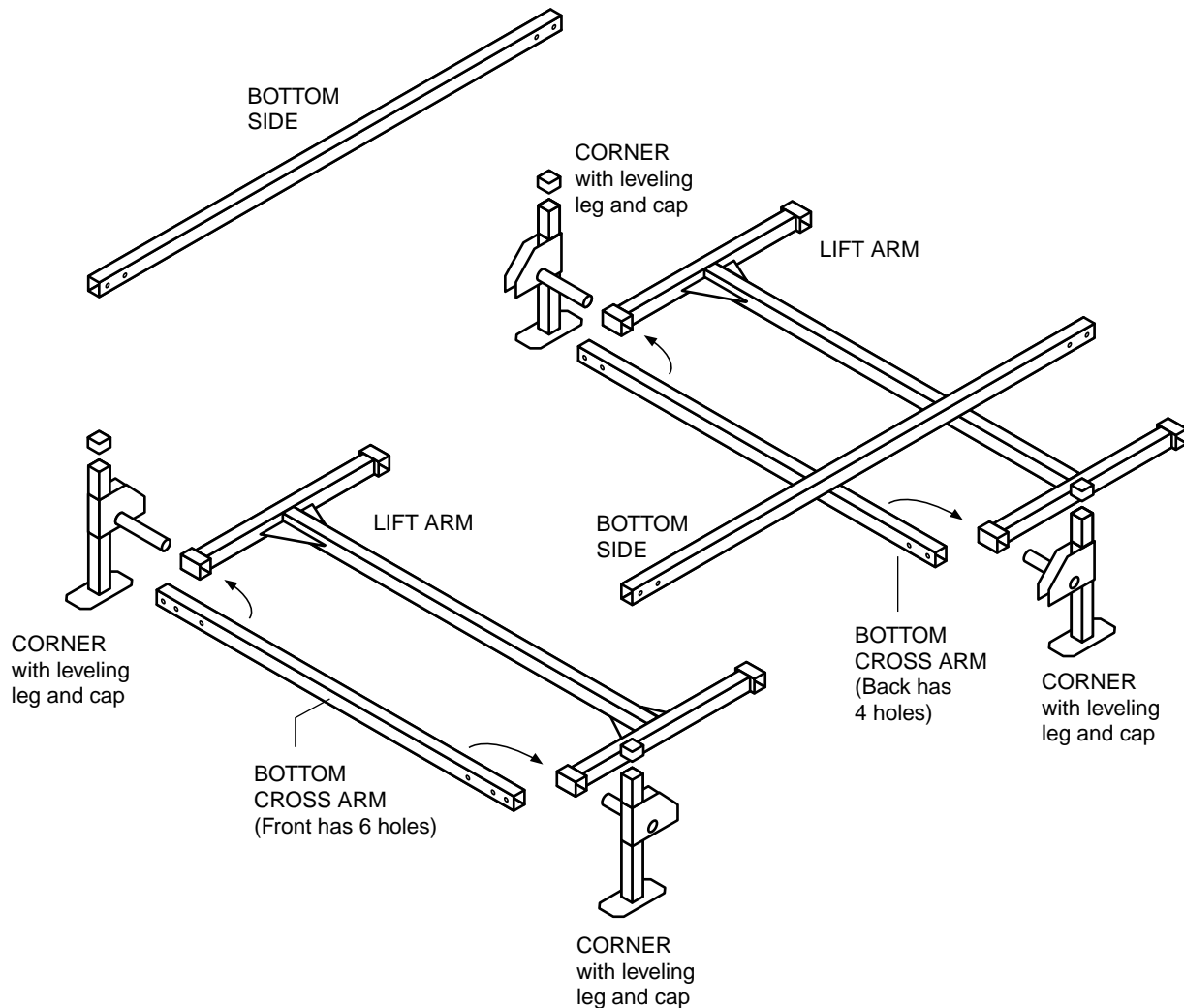

STEP 5: Pivot lift arms up into a vertical position. Caution: Temporarily brace the lift arms or have a helper hold them in the upright position to prevent injury. Assemble top cross arms and pull arms as shown. Make sure the pulley boxes on pull arms face downward. Also make sure the pulley boxes are toward the front of the lift. The front is the end with the bottom front cross arm, which has six bolt holes. Note: If you have difficulty pushing pull arms into the cross arms, use a rubber mallet or place a block of wood against pull arms and tap in with a hammer. To avoid damage, do not strike aluminum directly with a hammer. Install two bolts and nuts on front and back.

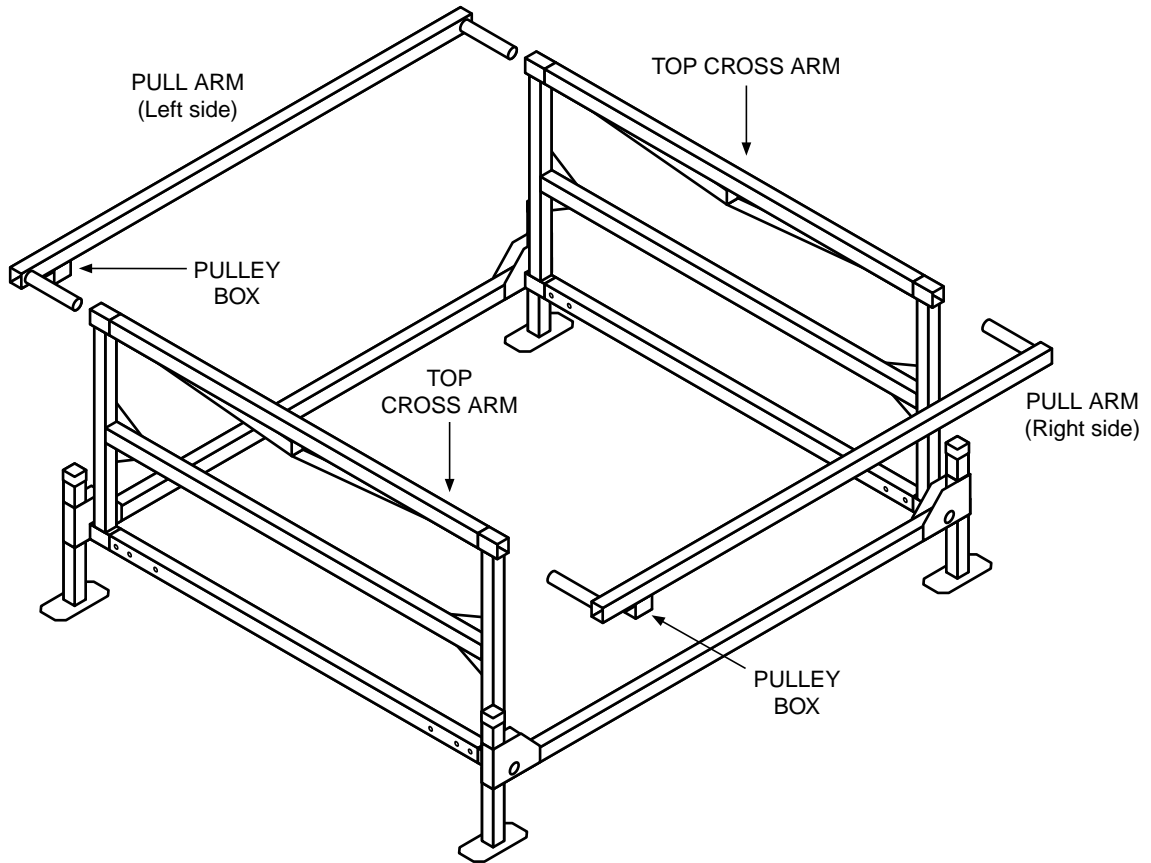

STEP 6 ONLY APPLIES TO THE 3000 113 x 151 LIFT.
For all other lifts, continue with STEP 7.

STEP 6: Bolt the four 87 7/8" top X-bracing flats under the cross arms, and join at center to form an X shape.

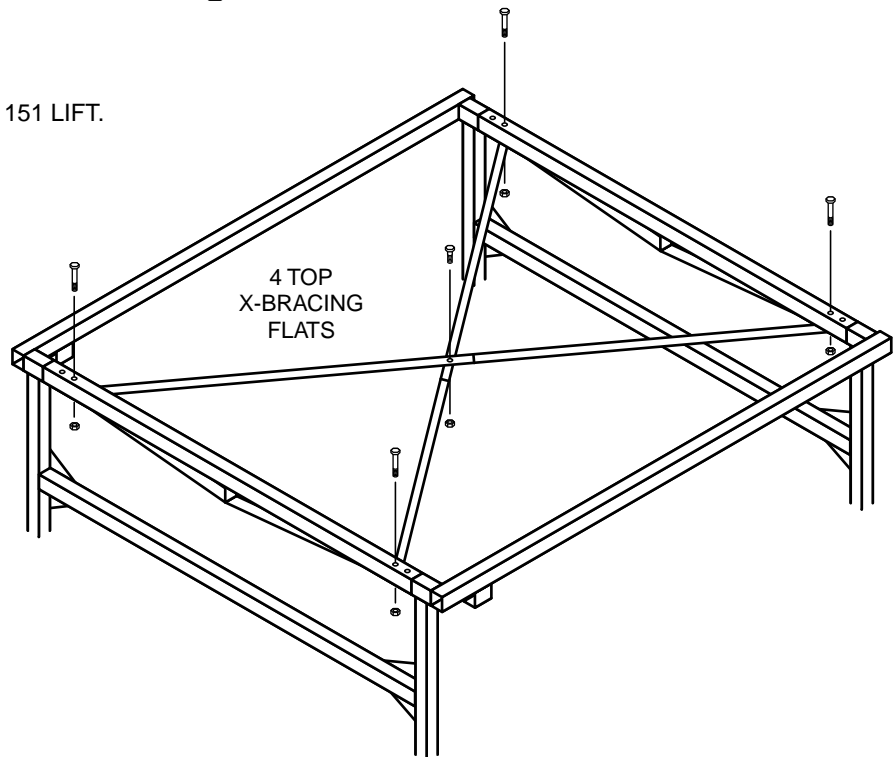

STEP 7. At this time, determine whether you want the winch mounted on the left or right side of the lift.

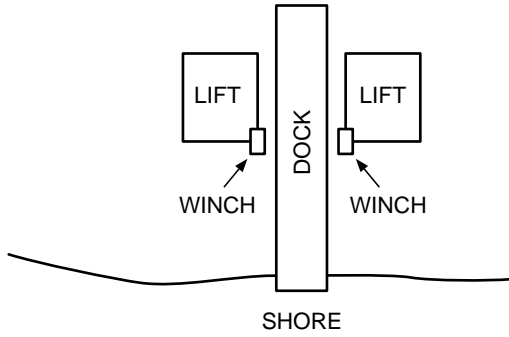

Attach the winch arm to the front corner on the side you have selected for mounting the winch. The winch arm has an identification sticker that gives the model number of the lift. Attach the front upright to the front corner on the opposite side of the lift.

STEP 8: Secure front lift arm to the winch arm and the front upright with a rope or strap while installing additional bracing, the cable and pulleys. There is one side 45° brace for each side of the lift. One end of each brace has a centered hole and the other end has an offset hole. Position the braces so the offset holes are at the rear of the lift and facing down. Starting with the non-winch side, insert one end of a side 45° brace into the rear corner bracket and the other between the welded plates on the front upright – secure with bolts and nuts. The brace for the winch side is installed in a similar manner, except the front bolt is also used to attach the guide pulley assembly – see diagram below.

STEP 9: Attach front side braces to bottom front cross arm and the front upright and winch arm.

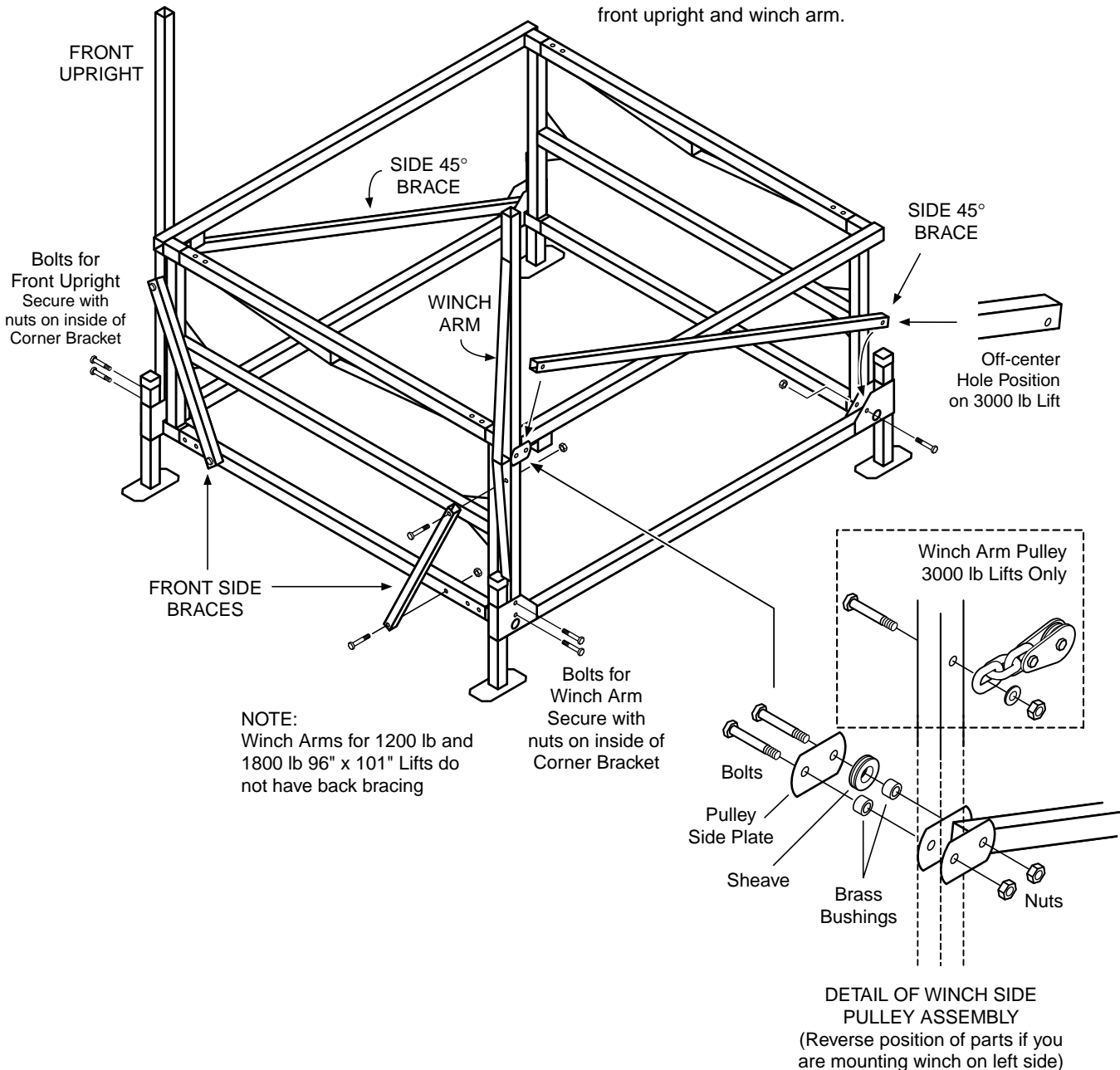

STEP 10: Bolt the complete pulley assemblies into the pulley boxes on the pull arms, **making sure they are slanted toward the outside** of the lift as shown. Use the two 1/2" x 4" (or 1/2" x 4 1/2") bolts with lock nuts. **Do not over-tighten, making sure the pulleys can move up and down freely.**

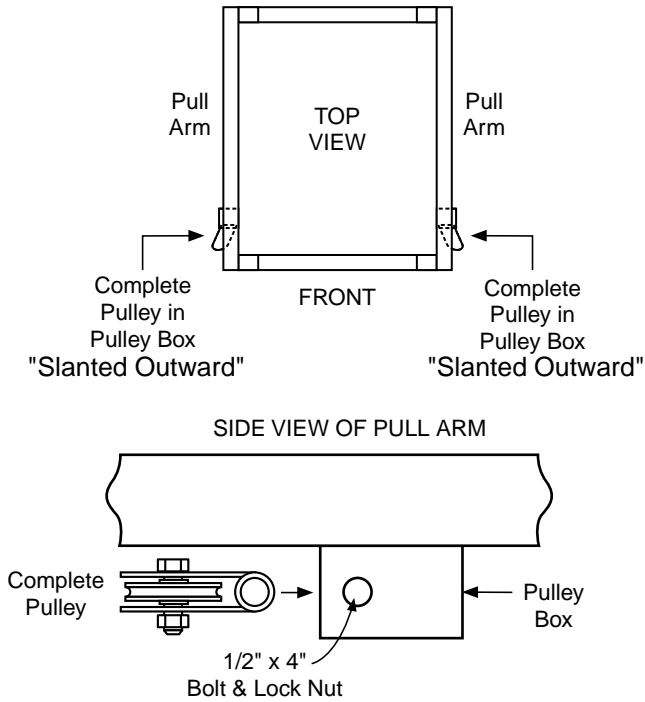

STEP 12: Attach cable to the winch cable drum using the clamp already attached to the drum. (Separate bolt bag with 1200 & 1800 lb lifts).

Cable installation: The winch turns clockwise when looking at the winch wheel. Route the cable over the winch drum in the direction the drum will rotate and under the cable clamp. A minimum of three full wraps of cable should be present before winch load is applied.

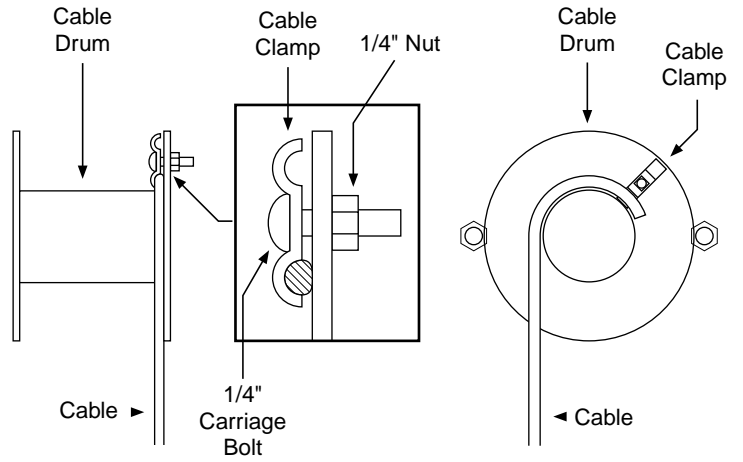

STEP 11: Mount the winch onto the side of the winch arm that faces the back of the lift. Attach winch with the aluminum winch reinforcement plate, two bolts and nuts as shown. Note: 1200 lb. lifts do not use this reinforcement plate. Tip: If installing a canopy, the canopy extension leg should be inserted into the winch arm while mounting the winch. See canopy assembly instructions for details.

STEP 13: String cable down from the winch, through the side guide pulley, through the complete pulley in the pull arm nearest the winch, and through the complete pulley on the opposite side of the lift. Wrap cable end around front upright two times and secure with cable clamp provided.

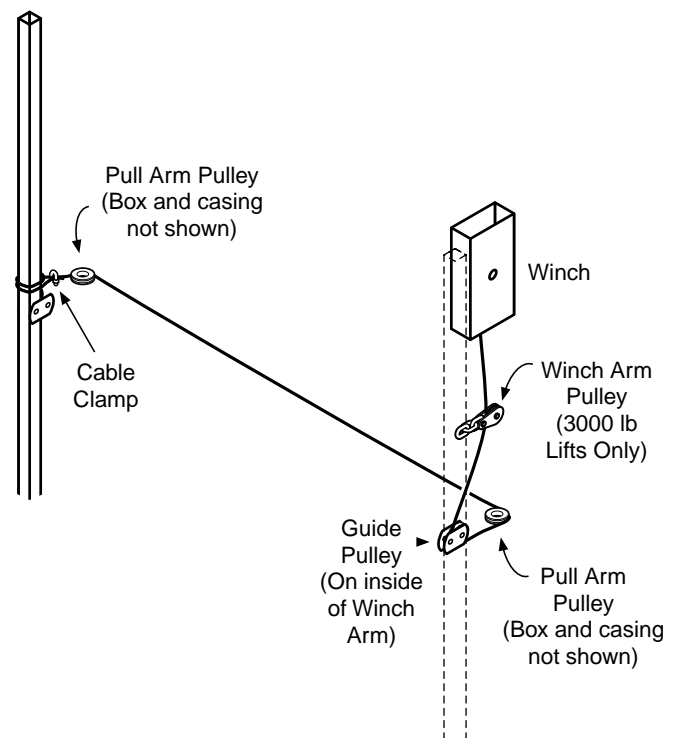
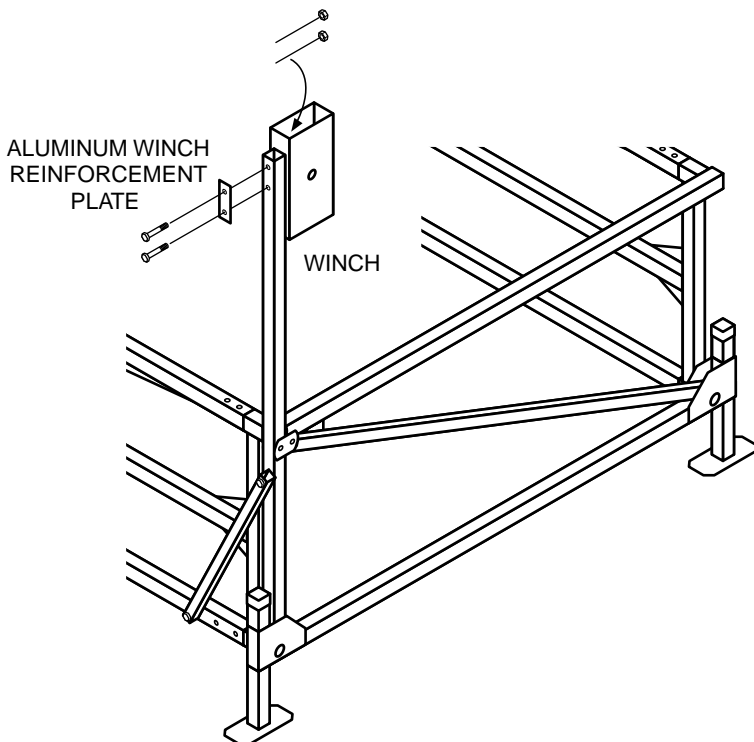

STEP 14: Install the spinner knob to the winch wheel as shown below.

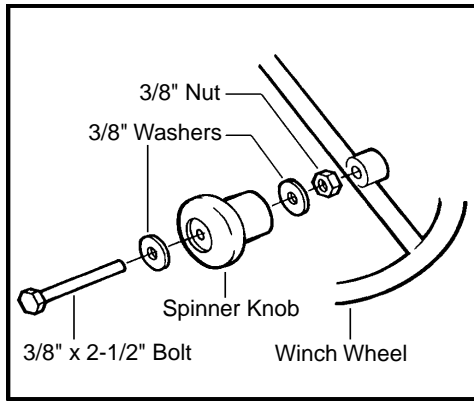

STEP 16: Mount the 12\"/>

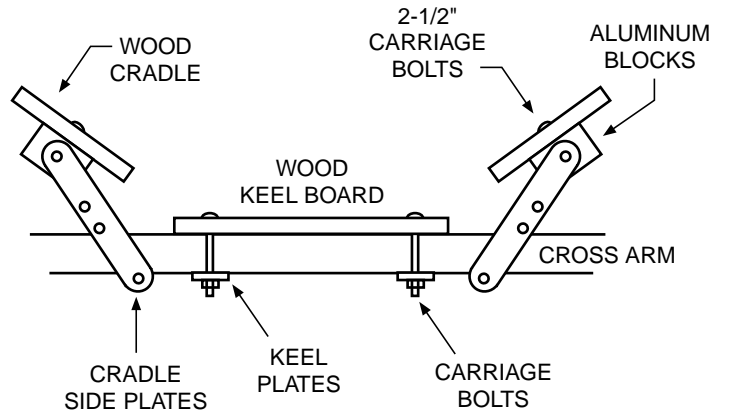

STEP 15: Attach the winch wheel to the winch. Grease the threads on the winch wheel so it is able to turn freely. Turn the wheel clockwise on the thread until it is tight against the winch. Fasten the winch wheel to the winch according to the model number below.

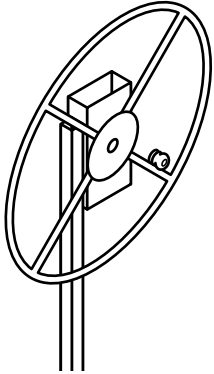

1200 lb., 1500 lb., and 1800 lb.

Use the hex bolt, retainer washer shaft and extension spring in the small parts bag.

2400 lb. and 3000 lb.

Use the hex bolt and washer provided on the winch threads.

For further details, see the instruction sheet supplied with your winch.

FULLY ASSEMBLED

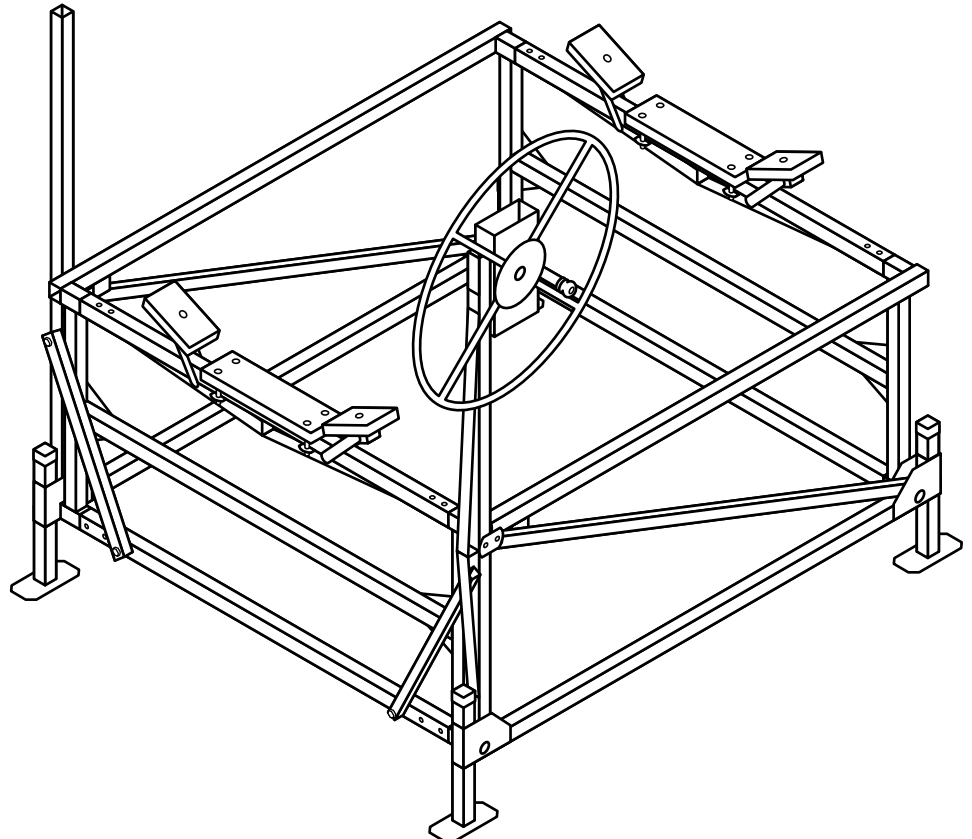

STEP 17: Tighten all bolts and nuts, and make sure that all pulley wheels turn and pivot freely.

STEP 18: Lastly – Turn the winch wheel clockwise until the slack cable is tight. **Be sure the cable windings are contained within the drum.** Remove any temporary strap or rope that was used to hold the lift arms upright during assembly.

WINCH OPERATION: To lift, turn the winch wheel clockwise. The brake ratchet pawl should produce a clicking sound. The winch will hold the load at any position. To lower the load, turn the wheel counter clockwise. **NEVER LIFT HUMAN BEINGS ON THE LIFT. NEVER ALLOW HUMAN BEINGS UNDER THE LIFT OR LOAD AT ANY TIME.**

WARNING: To avoid injury, never lift the ratchet pawl from the ratchet wheel. It must stay in contact with the wheel at all times.

NOTES:

- Grease the cable and the bushings yearly for longer life.
- Periodically check that the pulleys are turning freely.
- When installing lift, the bed should be nearly level with the rear of lift, only slightly lower than the front.
- When placing the boat on the lift, make sure the boat is brought forward as far as possible without over running the lift. (The stem should be close to the back of the rear cross arm)
- When operating the lift, **DO NOT**, continue to crank the winch after the lift bed is fully down. Doing so will cause the cable to loosen on the winch drum causing the cable to tangle when rewinding.
- Allow your boat to float off of the lift framework completely before attempting to load or unload your boat from the lift. Do not power on or off.

WARRANTY

New HEWITT-built boat and pontoon lifts carry a 15 year conditional warranty on all aluminum and aluminum welds, and a 5 year conditional warranty on canvases, excluding fading.

HEWITT Machine and Manufacturing, Inc. further warrants all other parts used on HEWITT-built lifts and accessories, purchased new by the original owner, to be free from defects in the material and workmanship under normal use for a period of 24 months from the date of purchase (excluding components and options which carry their own manufacturer's warranty, wherein that warranty will apply). There is no other express warranty. HEWITT Machine and Mfg. Inc. is not liable for incidental or consequential damages or injuries of any kind due to installation, removal, use, misuse, misapplication or improper selection of one of our purchased or displayed products. HEWITT agrees to repair or replace only defective parts returned to the factory (prepaid) and deemed defective by HEWITT. Warranty is void when misuse or neglect is the cause.

Specifications are subject to change without notice.

"Quality Since 1971"

HEWITT MACHINE & MFG, INC. Box 111 Nicollet, MN 56074 (507) 225-3421
www.hewitt-roll-a-dock.com e-mail: info@hewitt-roll-a-dock.com